

**DISPLAY Elektronik GmbH**

# DATA SHEET

**LCD MODULE**

## **DEM 160160A SBH-PW-N**

*Product Specification*

*Version : 4.1*

**29.01.2008**

# GENERAL SPECIFICATION

---

MODULE NO. :

## DEM 160160A SBH-PW-N

CUSTOMER P/N

VERSION NO.	CHANGE DESCRIPTION	DATE
0	ORIGINAL VERSION	08.06.2007
1	ADD PCB DESCRIPTION	12.06.2007
2	ADDING VERSION	15.06.2007
3	REVISE BACKLIGHT	10.09.2007
4	UPDATE ITEM 9. BACKLIGHT ELECTRICAL/OPTICAL SPECIFICATIONS	26.09.2007

PREPARED BY: ZWY

DATE: 26.09.2007

APPROVED BY: MH

DATE: 29.01.2008

**CONTENTS**

1. FUNCTIONS &FEATURES..... 1

2. MODULE ARTWORK ..... 2

3. EXTERNAL DIMENSIONS ..... 2

4. BLOCK DIAGRAM ..... 2

5. PIN ASSIGNMENT ..... 3

6. POWER SUPPLY..... 4

7. PBC DESCRIPTION..... 5

8. ABSOLUTE MAXIMUM RATINGS..... 4

9. BACKLIGHT ELECTRICAL/OPTICAL SPECIFICATIONS ..... 5

10. DC CHARACTERISTICS ..... 6

11. AC CHARACTERISTICS ..... 6

12. OPTICAL CHARACTERISTICS..... 9

13. LCD MODULES HANDLING PRECAUTIONS..... 11

14. OTHERS..... 11

## 1. FUNCTIONS & FEATURES

MODULE NAME	LCD TYPE
DEM 160160A SBH-PW-N	STN-BLUE Transmissive Negative Mode

- Viewing Direction : 6 'clock
- Driving Scheme : 1/160 Duty, 1/13 Bias,
- Supply voltage : 3.3 Volt (typ.)
- $V_{LCD}$  : 20.0 Volt (typ. @ 25°C)
- Backlight color : LED, Lightguide, White, Long-Lifetime
- Interface : 4-Bit-Parallel
- Drive IC : NT7701H - TABF2 (Novatek)
- Operating Temperature : -20°C to +70°C
- Storage Temperature : -40°C to +80°C

## 2. MODULE ARTWORK

- Module size : 76.50 x 71.50 x 10.40 mm
- LCD Active Area : 55.985 x 55.985 mm
- LCD Viewing Area : 61.50 x 61.5 mm
- Dot Pitch : : 0.35 x 0.35 mm
- Dot Size : : 0.335 x 0.335 mm
- Dot Gap : : 0.015 mm

## 3. EXTERNAL DIMENSIONS

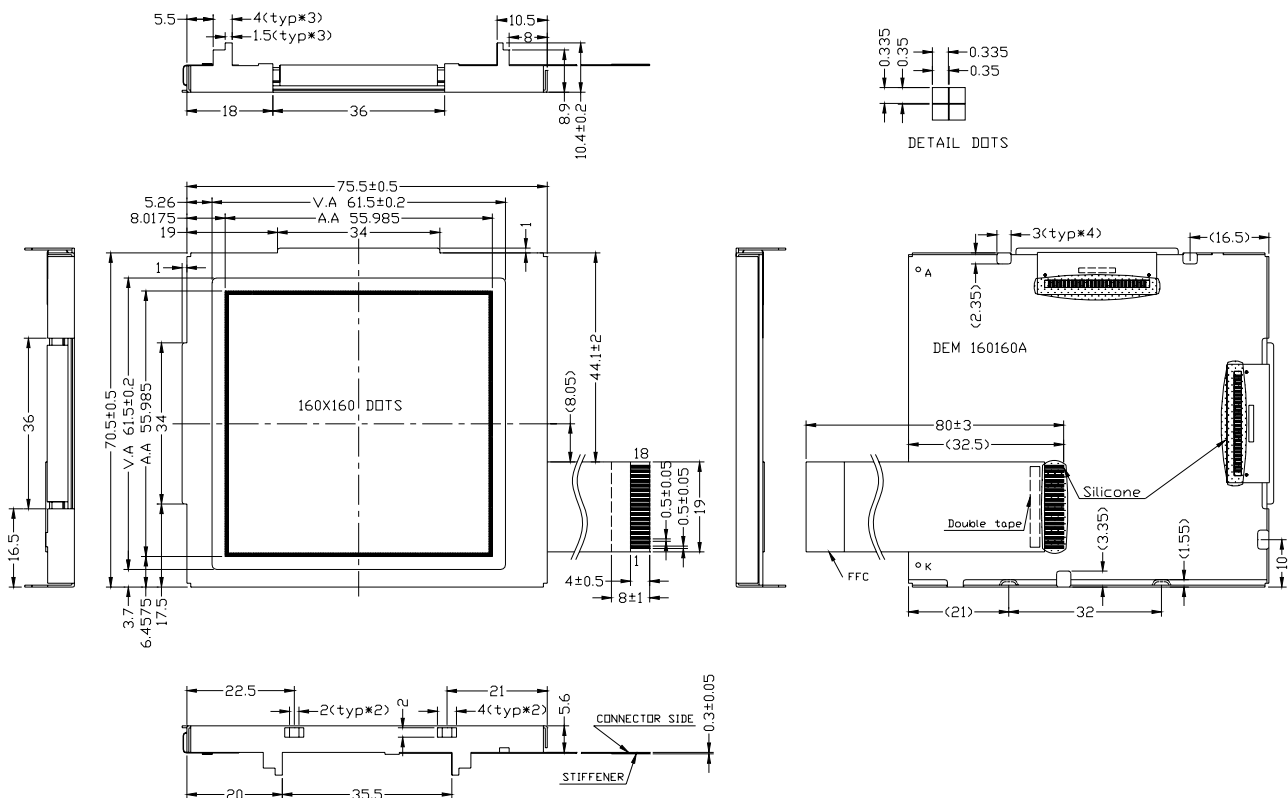

4. BLOCK DIAGRAM

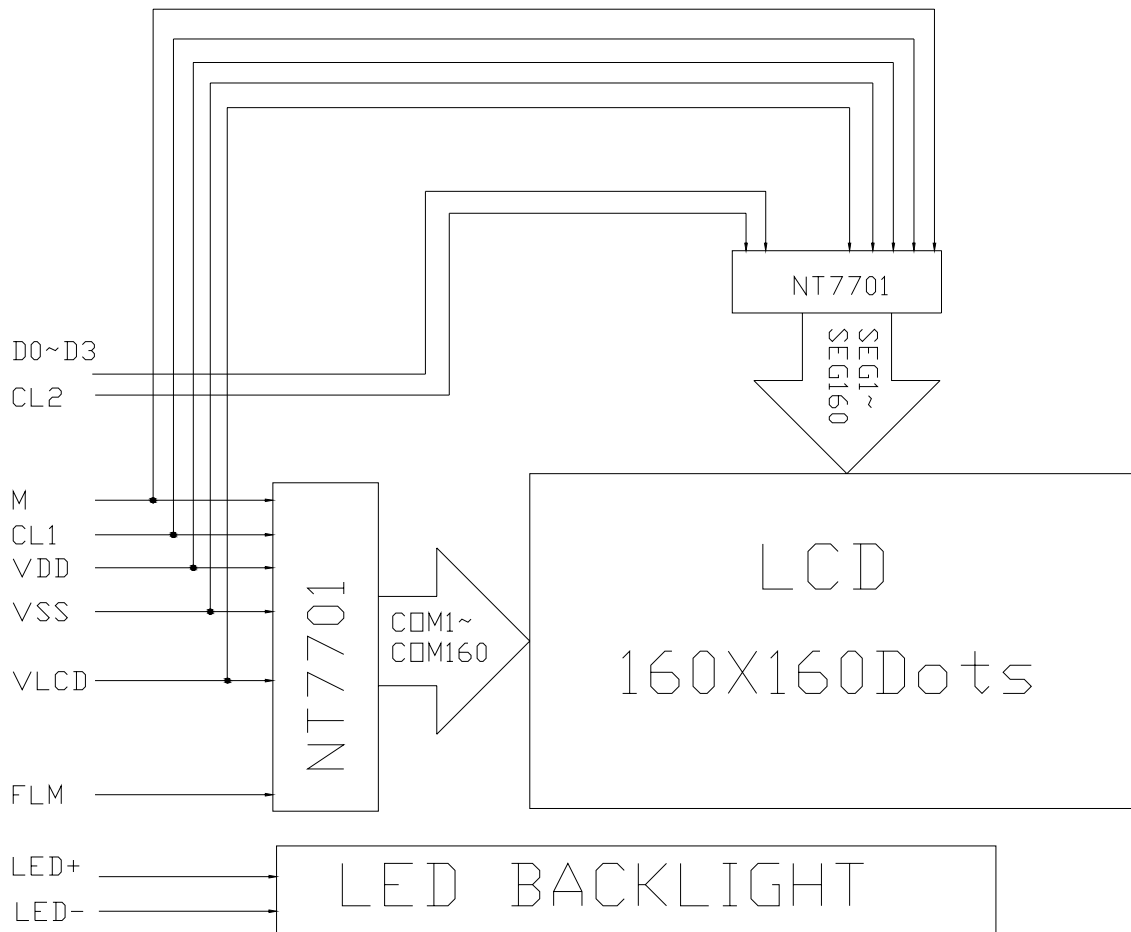

5. PIN ASSIGNMENT

PIN NUMBER	SYMBOL	FUNCTION
1	VSS	Ground
2	FLM	First line mark for common scan
3	CL1	H→L Data latch pulse
4	CL2	Clock pulse for segment shift register
5	M	H/L Frame reverse signal
6	VDD	H/L supply for logic (+3.3V)
7	NC	No connection
8	VEE	Power supply for LCD
9~12	D3~D0	Input data signal
13	NC	No connection
14	NC	
15	NC	
16	NC	
17	LED (+)	5 Volt (Anode of backlight, integrated LED-resistor) Please refer to Item 7-1
18	LED (-)	5 Volt (Cathode of backlight, integrated LED-resistor) Please refer to Item 7-1

6. POWER SUPPLY

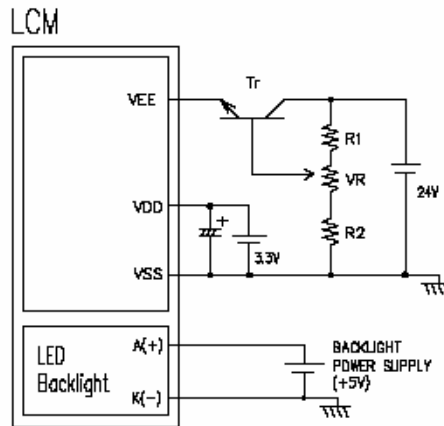

(NOTE)  $R1+R2+VR \approx 20K\Omega$

7. PCB DESCRIPTION:

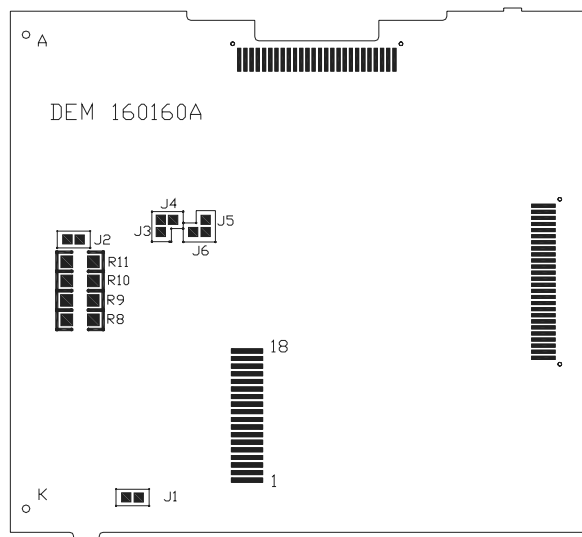

7-1.The polarity of the pin 17 and the pin 18:

J3,J5	J6, J4	LED Polarity	
		17 Pin	18 Pin
Each closed	Each open	Anode	Cathode
Each open	Each closed	Cathode	Anode

Note: In application module, J3=J5 =closed, J4=J6=open.

7-2. The J1 is metal-bezel GND to module GND.

Note: In application module, J1=closed.

7-3.The LED resistor should be bridged when J2 is closed.

Note: In application module, J2=open

7-4.The R8 and the R9, R10, R11 are the LED resistor.

Note: In application module → R8=33 Ohm and R9 = 68 Ohm.

8. ABSOLUTE MAXIMUM RATINGS

Parameter	Symbol	Min.	Max.	Unit
Supply voltage Logic	VDD	-0.3	7.0	V
Input voltage	--VI	-0.3	VDD+0.3	V
Supply voltage Vo	Vlcd	-0.3	30	
Operating Temperature	---	-20	+70	°C
Storage temperature	--	-40	+80	°C

9. BACKLIGHT ELECTRICAL/OPTICAL SPECIFICATIONS

9.1 Electrical-Optical Characteristics (Ta = 25°C)

Item	Symbol	MIN.	TYP.	MAX.	Unit	Condition
Forward Voltage	Vf		3.1	3.5	V	If = 15X6=90 mA
Colour Coordinate (Tolerances is ±0.01)	x	0.24		0.32	---	
	y	0.24		0.32	---	
Uniformity	Avg	70			%	
Luminance	Lv	500	600		cd/m <sup>2</sup>	
Reverse Current (Per LED)	Ir			50	μA	Vr = 5 V

9.2 Backlight Drawing

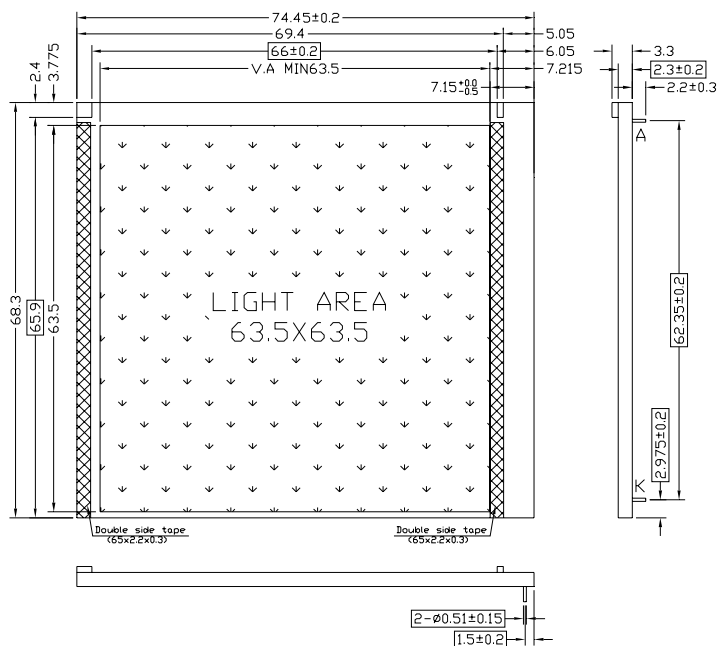

Remarks:  
 1, Unmarked tolerance is ±0.3,  
 2, The material comply with RoHS,  
 3, If = 15X6=90 mA, lifetime=50000hours;  
 If = 10X6=60 mA, lifetime=80000hours;  
 If = 8X6=48 mA, lifetime=100000hours.

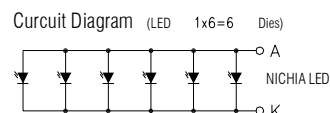

**10. DC CHARACTERISTICS**(V<sub>SS</sub>= 0V, Ta = -20 to +70°C)

Parameter	Symbol	Min.	Typ	Max	Unit
Supply Voltage Logic	V <sub>DD</sub>	2.5	3.3	5.5	V
Consumed current	I <sub>DD</sub>	---	TBD	---	mA
LCD driving voltage	--	19.6	20.0	20.4	V

**11. AC CHARACTERISTICS****11.1 NT7701 Segment Mode AC Characteristics**(V<sub>SS</sub>= 0V, Ta=-20~+70°C)

Parameter	Symbol	Min.	Typ.	Max.	Unit	Condition
Shift clock period	twck	125	-		ns	tr, tf ≤ 11ns, Note 1
Shift clock "H" pulse width	twckH	51	-		ns	
Shift clock "L" pulse width	twckL	51	-		ns	
Data setup time	tds	30	-		ns	
Data hold time	tdh	40	-		ns	
Latch pulse "H" pulse width	twlph	51	-		ns	
Shift clock rise to Latch pulse rise time	tLD	0	-		ns	
Shift clock fall to Latch pulse fall time	tsL	51	-		ns	
Latch pulse rise to Shift clock rise time	tLs	51	-		ns	
Latch pulse fall to Shift clock fall time	tLH	51	-		ns	
Input signal rise time	tr		-	50	ns	Note 2
Input signal fall time	tr		-	50	ns	Note 2
Enable setup time	ts	36	-		ns	
$\overline{\text{DISPOFF}}$ Removal time	tsD	100	-		ns	
$\overline{\text{DISPOFF}}$ enable pulse width	twDL	1.2	-		μs	
Output delay time (1)	td		-	78	ns	CL = 15pF
Output delay time (2)	tpd1, tpd2		-	1.2	μs	CL = 15pF
Output delay time (3)	tpd3		-	1.2	μs	CL = 15pF

## Note

1. Take the cascade connection into consideration.
2. (tck - twckH - twckL)/2 is the maximum in the case of high speed operation.



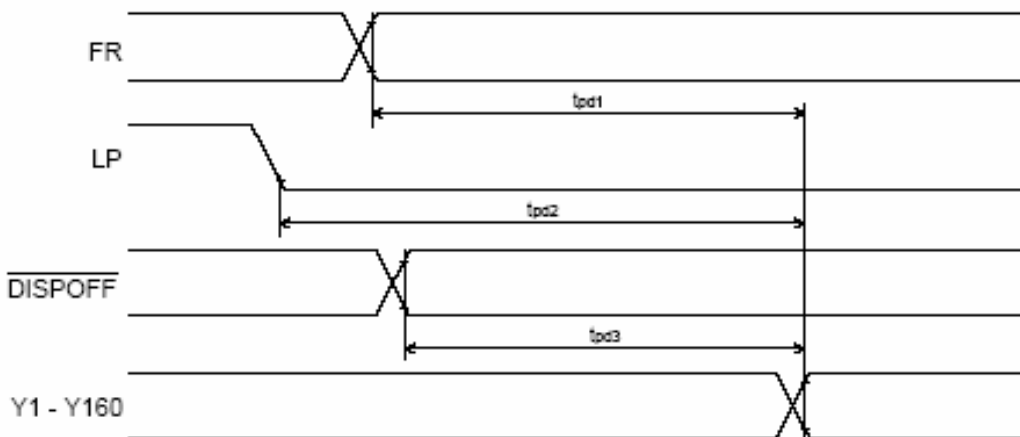
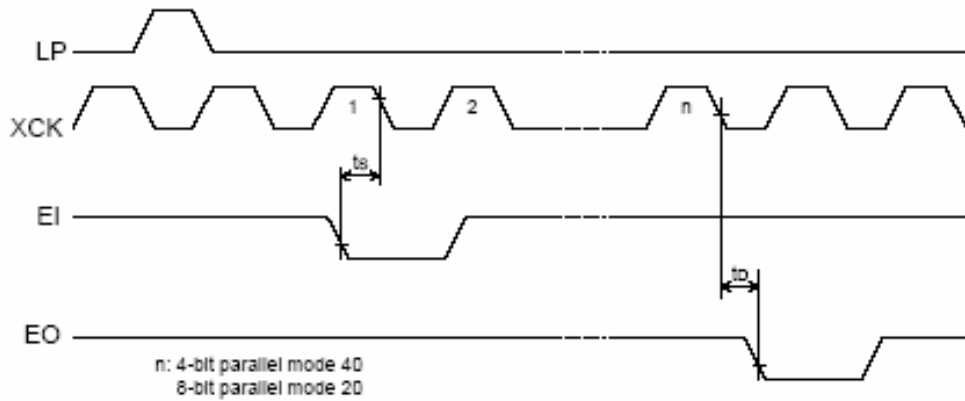
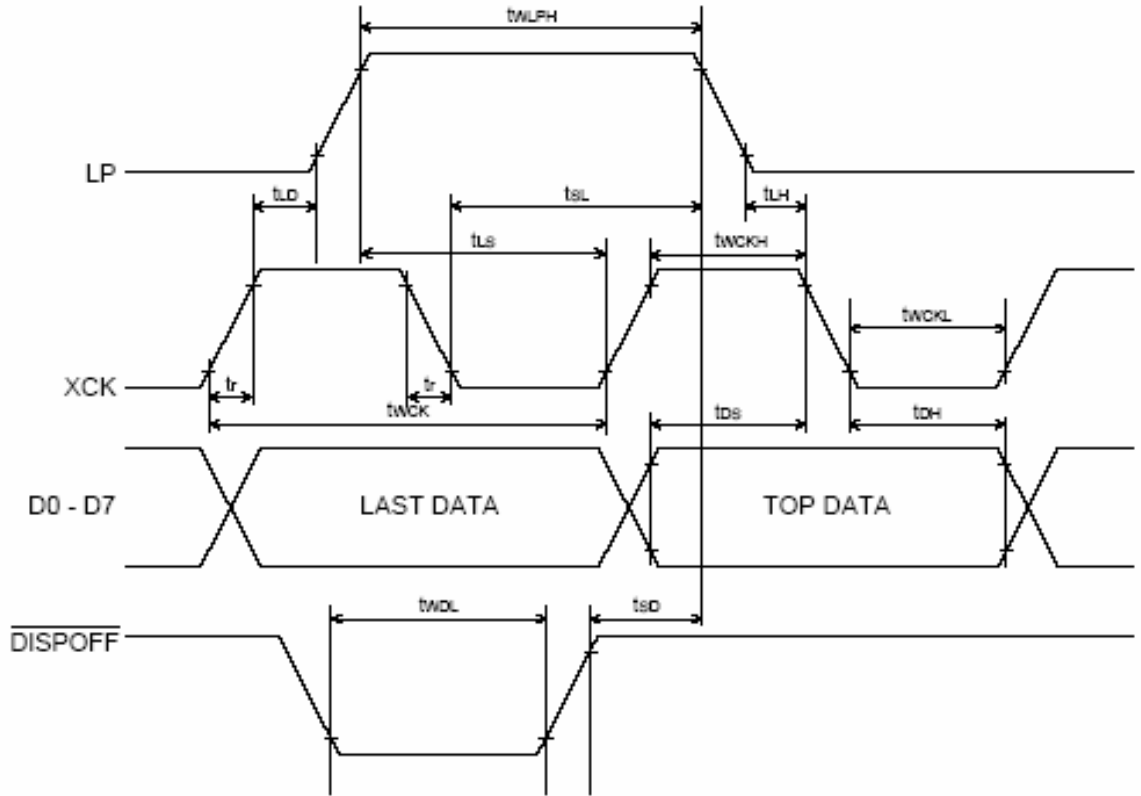

Timing Characteristics of segment Mode

11.2 NT7701 Common Mode AC Characteristics

( $V_{SS} = 0V$ ,  $T_a = -20 \sim +70^\circ C$ )

Parameter	Symbol	Min.	Typ.	Max.	Unit	Condition
Shift clock period	tWLP	250	-	-	ns	$t_r, t_f \leq 20ns$
Shift clock "H" pulse width	tWLPH	15	-	-	ns	$V_{DD} = +5.0V \pm 10\%$
		30	-	-	ns	$V_{DD} = +2.5 \sim +4.5V$
Data setup time	tSU	30	-	-	ns	
Data hole time	tH	50	-	-	ns	
Input signal rise time	t <sub>r</sub>		-	50	ns	
Input signal fall time	t <sub>f</sub>		-	50	ns	
$\overline{DISPOFF}$ Removal time	tSD	100	-	-	ns	
$\overline{DISPOFF}$ enable pulse width	tWDL	1.2	-	-	$\mu s$	
Output delay time (1)	tDL	-	-	200	ns	$C_L = 15pF$
Output delay time (2)	t <sub>pd1</sub> , t <sub>pd2</sub>	-	-	1.2	$\mu s$	$C_L = 15pF$
Output delay time (3)	t <sub>pd3</sub>	-	-	1.2	$\mu s$	$C_L = 15pF$

Timing Characteristics of Common Mode

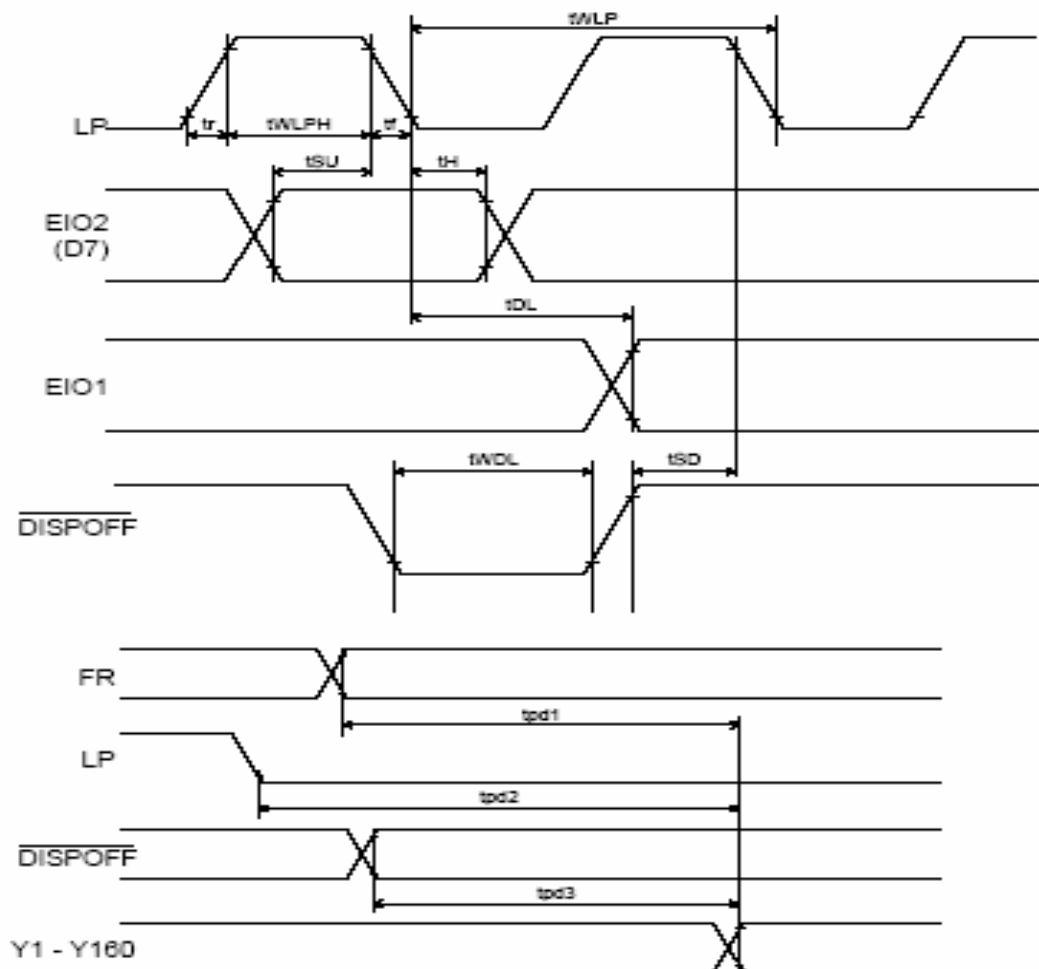

**12. OPTICAL CHARACTERISTICS**

**12.1 Overall optical performance**

Positive display

ITEM	SYMBOL	CONDITIONS	TYP.	UNIT	REMARKS
Viewing angles for Contrast Ratio CR > 3	$\alpha$	$\Phi = 0^\circ$ $\Phi = 90^\circ$ $\Phi = 180^\circ$ $\Phi = 270^\circ$	50 40 50 45	°	Transmissive operation

Definition of viewing angles  $\Phi, \alpha$  and contrast ratio  $\square R$

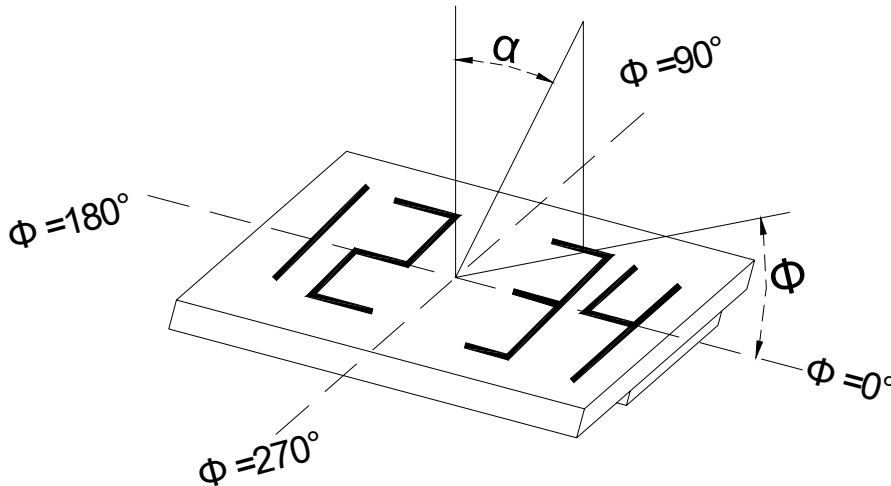

Contrast ratio  $\square R = \frac{\text{Brightness of OFF-segments}}{\text{Brightness of ON-segments}}$

**12.2 Response times at different temperatures**

Response times  $t_{on}$  and  $t_{off}$  are measured using simulated MUX at  $f=f_{FRAME}$ .  $V_{op}$  (+25°C) will be identical to  $V_{op}$  (+25°C) as specified for the viewing angles.

Item	Symbol	Conditions	Min.	Typ.	Max.	Unit	Remarks
Response Times	$t_{on}$	$T_{amb} = -20^{\circ}C$	TBD	TBD	TBD	ms	$\alpha = 0^{\circ}, \Phi = 0^{\circ}$
		$0^{\circ}C$	TBD	TBD	TBD	ms	
		$25^{\circ}C$	TBD	TBD	TBD	ms	
		$50^{\circ}C$	TBD	TBD	TBD	ms	
		$70^{\circ}C$	TBD	TBD	TBD	ms	
	$t_{off}$	$T_{amb} = -20^{\circ}C$	TBD	TBD	TBD	ms	
		$0^{\circ}C$	TBD	TBD	TBD	ms	
		$25^{\circ}C$	TBD	TBD	TBD	ms	
		$50^{\circ}C$	TBD	TBD </td <td>TBD</td> <td>ms</td>	TBD	ms	
		$70^{\circ}C$	TBD	TBD	TBD	ms	

Remark: value will be measured after sampling.

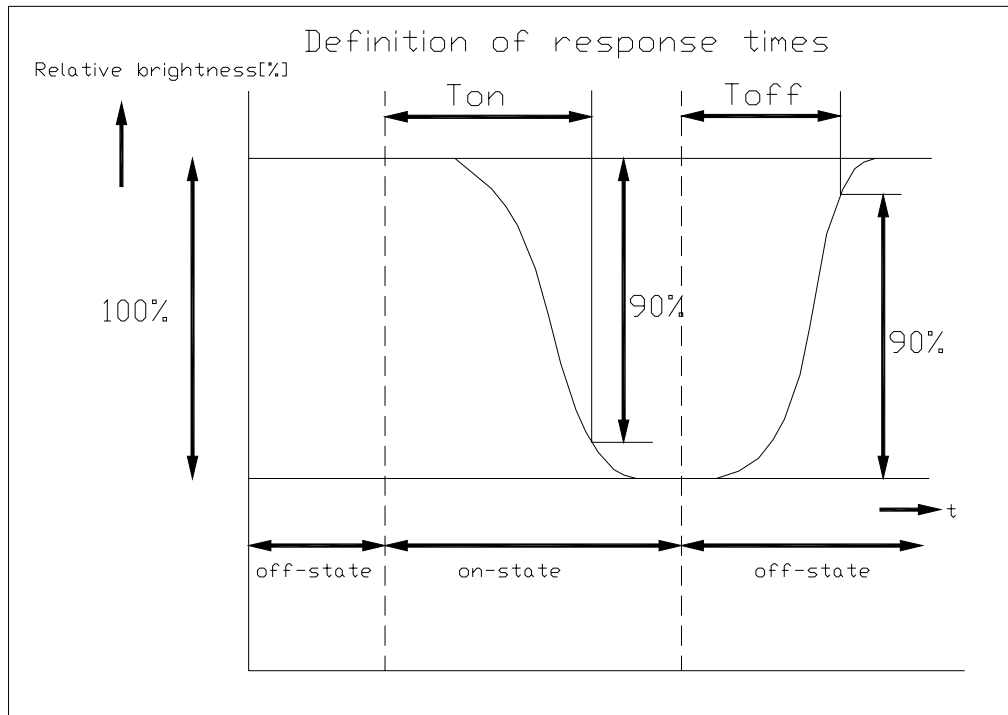

### **13 LCD MODULES HANDLING PRECAUTIONS**

- Please remove the protection foil of polarizer before using.
- The display panel is made of glass. Do not subject it to a mechanical shock by dropping it from a high place, etc.
- If the display panel is damaged and the liquid crystal substance inside it leaks out, do not get any in your mouth. If the substance come into contact with your skin or clothes promptly wash it off using soap and water.
- Do not apply excessive force to the display surface or the adjoining areas since this may cause the color tone to vary.
- The polarizer covering the display surface of the LCD module is soft and easily scratched. Handle this polarize carefully.
- To prevent destruction of the elements by static electricity, be careful to maintain an optimum work environment.
  - Be sure to ground the body when handling the LCD module.
  - Tools required for assembly, such as soldering irons, must be properly grounded.
  - To reduce the amount of static electricity generated, do not conduct assembly and other work under dry conditions.
  - The LCD module is coated with a film to protect the display surface. Exercise care when peeling off this protective film since static electricity may be generated.
- Storage precautions  
When storing the LCD modules, avoid exposure to direct sunlight or to the light of fluorescent lamps. Keep the modules in bags designed to prevent static electricity charging under low temperature / normal humidity conditions (avoid high temperature / high humidity and low temperatures below 0°C). Whenever possible, the LCD modules should be stored in the same conditions in which they were shipped from our company.

### **14. OTHERS**

- Liquid crystals solidify at low temperature (below the storage temperature range) leading to defective orientation of liquid crystal or the generation of air bubbles (black or white). Air bubbles may also be generated if the module is subjected to a strong shock at a low temperature.
- If the LCD modules have been operating for a long time showing the same display patterns may remain on the screen as ghost images and a slight contrast irregularity may also appear. Abnormal operating status can be resumed to be normal condition by suspending use for some time. It should be noted that this phenomena does not adversely affect performance reliability.
- To minimize the performance degradation of the LCD modules resulting from caused by static electricity, etc. exercise care to avoid holding the following sections when handling the modules:
  - Exposed area of the printed circuit board
  - Terminal electrode sections.